

 **Sealed Air**

# Fill-Air<sup>®</sup> 2000

Inflatable Packaging System



**The fast, user-friendly, packaging system**  
Designed to be on-line all the time

# Fill-Air® 2000 Inflatable Packaging System

Create variable cushion sizes with unmatched speed and ease of use



## Fast, efficient, void fill packaging

The Fill-Air® 2000 system is Sealed Air's premier void fill packaging solution. The Fill-Air® 2000 system creates inflatable packaging on demand, at a speed of up to **200 cushions per minute**.

Increased speed and throughput make the Fill-Air® 2000 system the easy choice for on-line packaging operations.



## Convenient and versatile inflatable packaging

The Fill-Air® 2000 system creates cushions in six different sizes, with the ability to change between 100mm and 200mm at the touch of a button. Our landscape sizes, such as the 300mm x 100mm cushion, fill small voids more efficiently.



Create various cushion sizes with the Fill-Air® 2000 system.

## Easy to use

The Fill-Air® 2000 system features a user-friendly control pad, allowing operators to quickly select the ideal cushion size. Cushion sizes can be changed mid-production without changing the film roll, saving time and warehouse space. Maintenance is quick and easy, with sealing components that snap into place.

## Ideal for on-line applications

Integrating the Fill-Air® 2000 system into a packaging line is simple and efficient. The system is all-electric; no shop air is required, making it easy to install in any packaging location. The auto-replenishment sensor maintains a constant supply of cushions, ensuring that material is readily available. The optional material stand allows the operator to position the material directly above the cartons to be packed.

## Increase productivity, reduce systems

One Fill-Air® 2000 system can support multiple packaging stations or multiple packaging lines. Multiple packaging lines can converge into a single, centralized line serviced by one Fill-Air® 2000 system. Likewise, material can be collected in bins and distributed to packaging stations, or it can be conveyed through a Sealed Air engineered overhead delivery system.

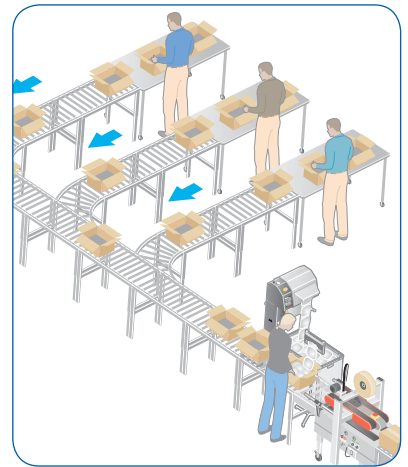

## Specifications

**Electrical:**  
220-240 V. Single Phase  
3-5 Amp. 50 Hz

**Weight (without roll):**  
90 kg

**Overall Size (W x D x H):**  
810mm x 760mm x 1470mm

**Optional Bin:**  
914mm x 533mm x 737mm

| Film     | Width |
|----------|-------|
| FA2K-200 | 200mm |
| FA2K-250 | 250mm |
| FA2K-300 | 300mm |

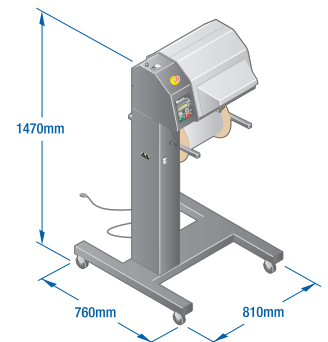

## Sealed Air

Protective Packaging  
Telford Way, Kettering, Northants NN16 8UN, UK  
Tel: +44 (0)1536 315700 Fax: +44 (0)1536 410576  
E-mail: PPDeuromktg@sealedair.com  
www.fill-air.eu

**Our Products Protect Your Products®**

Distributed by:

Corporate offices: Sealed Air Corporation,  
200 Riverfront Boulevard, Elmwood Park, NJ 07407, USA  
www.sealedair.com

Sealed Air has companies throughout the world.  
© Sealed Air Corporation 2007. All rights reserved.

